

角ます

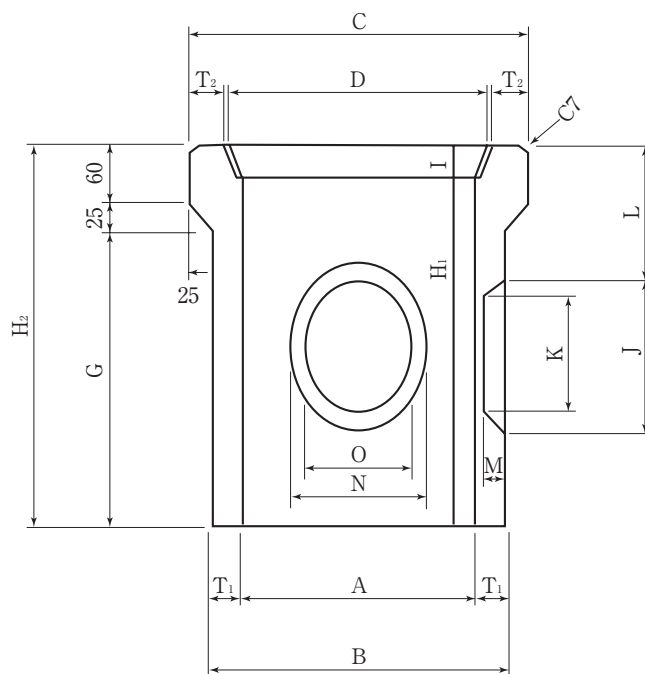

蓋

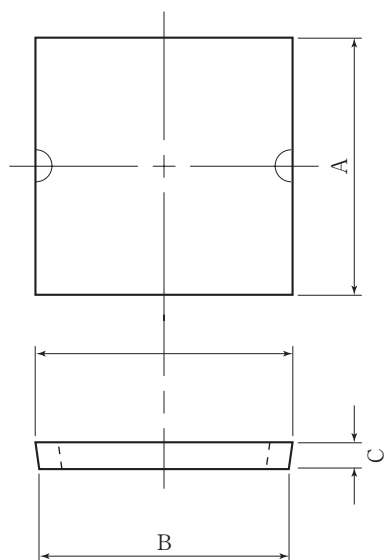
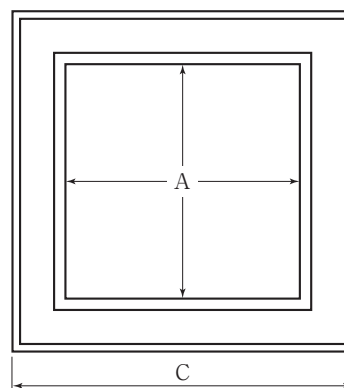

仕様寸法表(単位mm)

呼び	A	B	C	重量(kg)
240	274	264	33	5
300	344	334	36	9
360	404	394	40	13
450	504	494	45	23
600	635	625	60	54

※グレーチング蓋、格子蓋もあります。

仕様寸法表(単位mm)

	A	B	C	D	G	H ₁	H ₂	I	J	K	L	M	N	O	T ₁	T ₂	重量(kg)
240	240	305	355	275	285	337	370	33	185	160	95	9	130	105	33	38	27
300A	300	360	420	344	345	394	430	36	185	160	125	9	135	110	30	40	36
300B	300	360	420	344	451	464	500	36	235	210	250	9	135	110	30	40	42
300C	300	360	420	344	551	564	600	36	350	310	240	9	140	110	30	40	51
360	360	432	482	405	405	450	490	40	210	190	140	9	160	140	36	46	67
450	450	530	580	505	515	555	600	45	240	220	180	9	190	170	40	45	93
600	600	700	750	634	515	540	600	60	400	365	220	15	285	250	50	55	228